

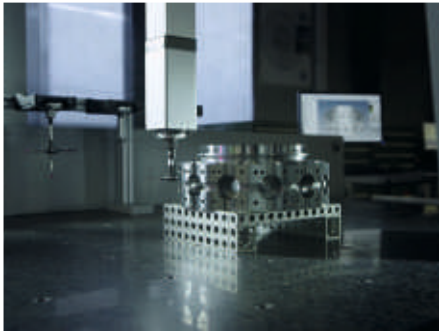

Machine tools

The complete machine range for turning, milling and grinding

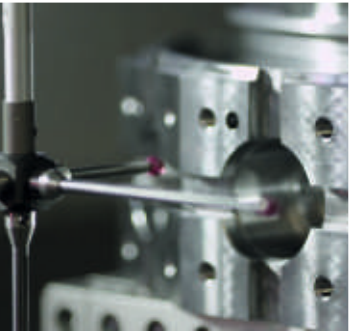

Model range



Tradition in Mechanical Engineering

[www.spinner.eu.com](http://www.spinner.eu.com)  
[sales@spinner.eu.com](mailto:sales@spinner.eu.com)

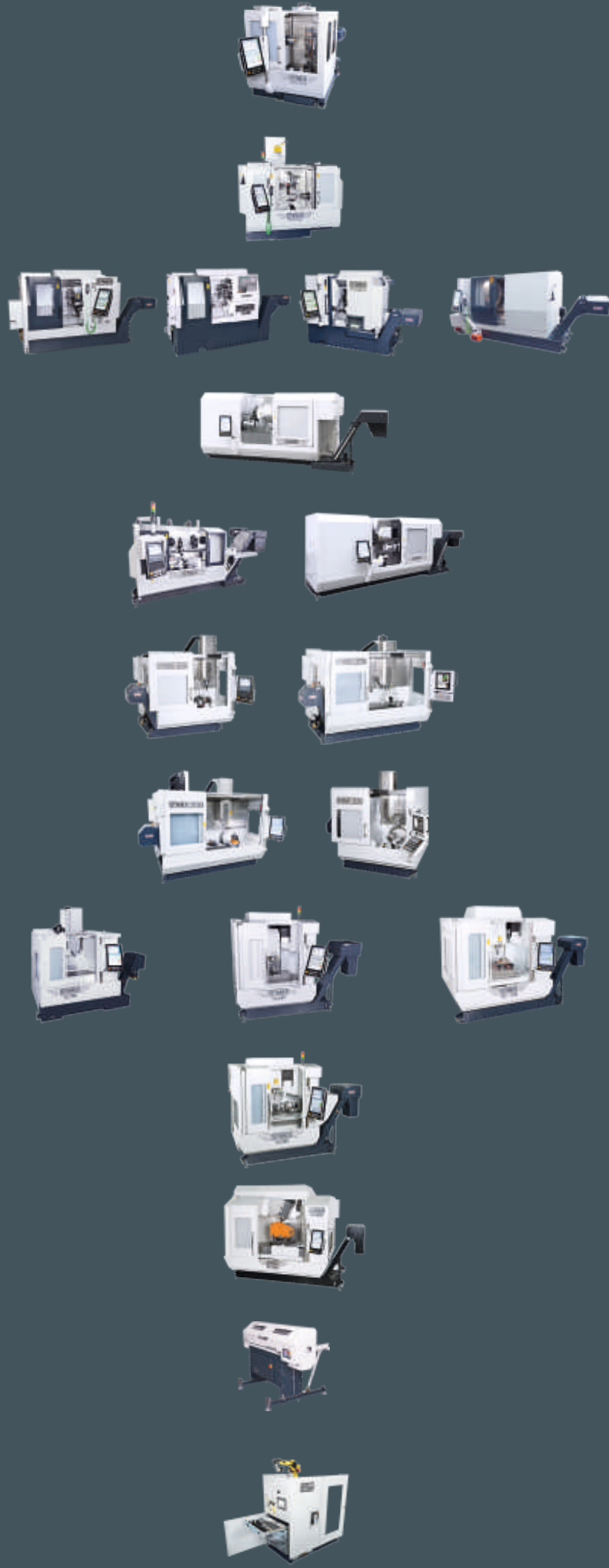

4

**Microturn:**

Turning-Milling Centre for complete precision machining AND micro-finishing

6

**Microturn Grind:**

Hard-turning and Grinding centre for micro-finishing

8

**TC series:**

Powerful Universal Lathe for high cutting performance

10

**TS Series:**

High-performance Universal Lathe for powerful and universal machining

12

**TTS series:**

High Productive Turning Centre for simultaneous machining with up to four turrets

14

**U-Compact-Line series:**

Travelling-Column Machining Centre with 3, 4 or 5-axes-machining, the entry-level to the superior milling class

16

**U-Advanced series:**

Travelling-Column Machining Centre with up to 5 axes, for high-end applications in the 5-axes simultaneous machining and the series production

18

**VC-3A series:**

High-Speed Machining Centre for demanding tasks in the workshop and in tool and mould making

20

**VC850-4A/5A series:**

Ultra compact 4-/5-axes machining centre

22

**VC1650-5A series:**

5-Axes Precision Machining Centre for large workpieces

24

**Bar feeders:**

Specially for SPINNER CNC-Lathes designed bar-loading system

25

**Robobox:**

Flexible, low-cost automation

26

**Automation:**

Integrated standard solutions with robot or individual solution, ALL FROM ONE SOURCE

## Turning

*We have been perfecting and improving our machine tools for more than 70 years. Today, more than 600 employees in the SPINNER GROUP complete more than 1,000 machine tools each year. SPINNER machines are successfully being used in more than 60 countries of the world.*

*In order to satisfy your requirements, we offer a wide range of Turning Machine and Machining Centre products. Tens of thousands of customers throughout the world trust in our CNC machine tools.*

*Our machine tools are always used where a particular demand in precision and reliability is required. Innovation and practical solutions in detail are guaranteed by our extensive construction department. We manufacture all important components and assemblies ourselves in our production plants in order to be able to supply you with machine beds, guideways, spindles and turrets that are perfectly matched to one-another.*

*Our machine tools are sophisticated seriesbuilt products manufactured at a high level. High precision standards in all areas of the production and assembly ensure for the optimum constant quality of our products. Each machine is subjected to a strict final inspection of all parameters.*

*We supply turnkey projects with automation for large-scale production. In order to ensure that the use of our machine tools is successful, we offer training courses for the operation, programming and maintenance of our systems.*

*Our service hotline deals with technical queries concerning the programming and repair of your SPINNER machine tools at any time and at short notice.*

*Place your trust in our products as well and let us know what we can do for you.*



## Milling



## Grinding



## Automation



# Microturn

Micro-finishing  
Hard-turning  
Universal machining

## Turning-Milling Centre for complete machining



- In X 600mm and Z 350mm moveable spindles for high rigid and optimised positioning  $< 1 \mu\text{m}$
- Direct measurement system for all axes
- Static linear table for standard linear tooling or special tools
- High precision motor spindles "Made by SPINNER"
- High-precision hard-turning

Linear tooling system for micro-finishing in combination with turret and Y-axis for universal machining.

Expandable to a 5-axes Turning-Milling centre for machining all 6 workpiece sides.

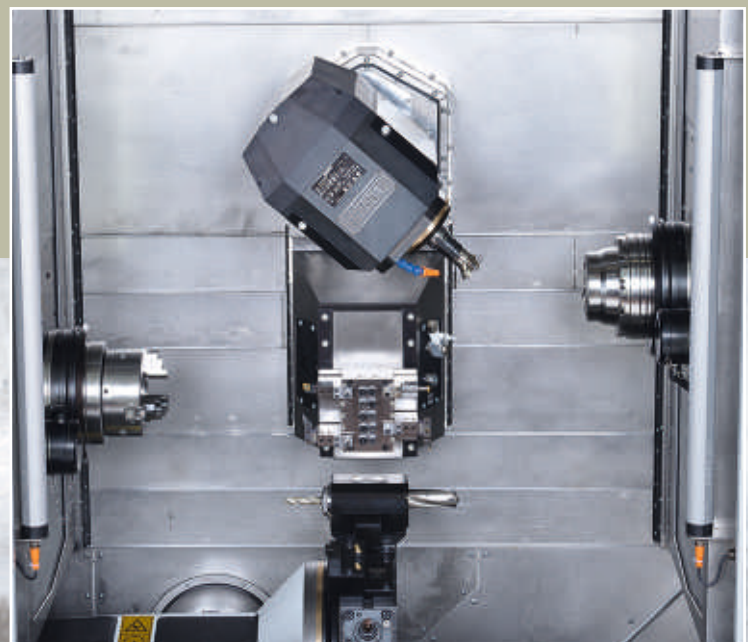

Version with subspindle and B-axis (LTBS-version)

# Microturn

With Y-axis  
With B-axis and milling spindle  
Available with sub-spindle

## AND micro-finishing

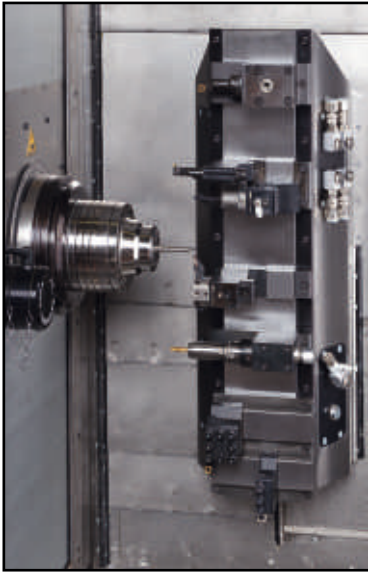

### L-Version

Spindle with high precision positioning in X1/Z1 and linear tooling as optimal rigid hard-turning and micro-finishing machine



### LT-Version

With additional turret with driven tools and Y1-axis in the lower part of the workspace



### LTB-Version

With additional milling spindle with Y2 and B-axis in the upper part of the workspace and with tool magazine up to 72 tools

**Unique combination of universal soft machining up to 5-axes Turning-Milling AND high-precision hard-turning machine in a single machine concept.**

### LTBS-Version

With two spindles on symmetrically positioned slides X2/Z2, also for simultaneous machining with sub-spindle (see picture on page 6 below)

### Strokes

	X-axis	Y-axis	Z-axis	B-axis	Turret
L-Version	600 mm	-	350 mm	-	-
LT-Version	600 mm	+/- 50 mm	350 mm	-	12 x BMT45
LTB(S)-Version	600 mm	+/- 50 mm	350 mm	+/- 180°	12 x BMT45

# Microturn Grind



Hard-turning  
External cylindrical grinding  
Internal cylindrical grinding

## Hard-turning and Grinding centre for micro-finishing



Unique combination of universal soft and hard-turning offering the possibilities of both an external and internal cylindrical grinding machine.

The picture opposite shows the Microturn Grind as a double spindle machine with transfer from spindle 1 to spindle 2 and simultaneous machining on both sides. Also available as a single-spindle machine. Also available with automation.



Sample workpiece

- Partial or pre-machining by hard-turning
- Shortened grinding time thanks to pre-machining with minimum stock oversize allowance
- Automatic dressing functions for grinding wheels
- Extensive grinding cycles programmed in the dialog
- Complete machining using both technologies in one operation

Hard-turning operation on left-hand workpiece spindle  
Simultaneous internal grinding operation on right-hand spindle

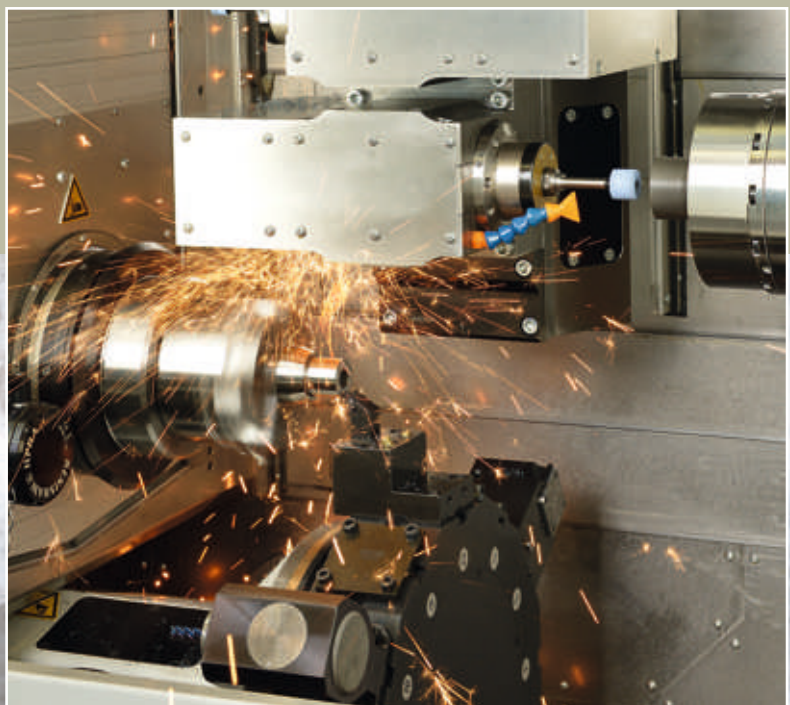

# Microturn Grind

with main and sub spindle  
with large grinding wheel  
on both spindles

## Single spindle or two spindles

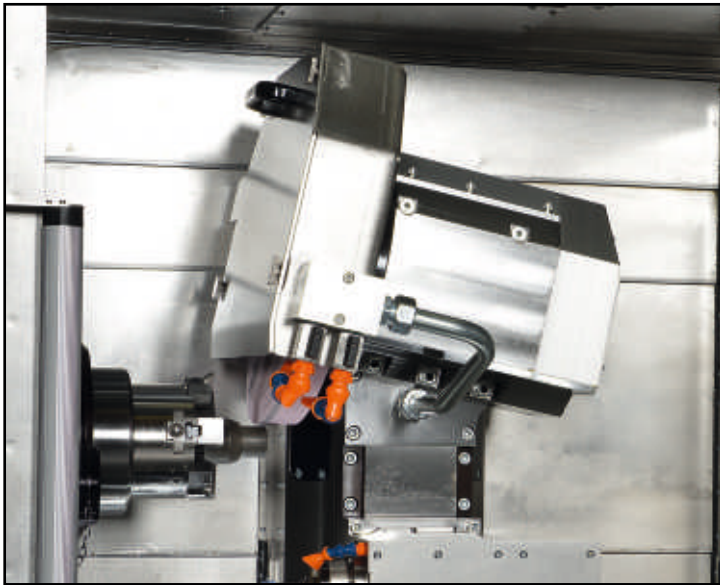

External grinding with powerful grinding spindle in angular plunge-cut, also suitable for face grinding of shoulders.

With integrated automatic balancing unit and CNC dressing device.

Also for polygon grinding of out-of-round contours.

Up to two high-performance internal grinding spindles up to 90,000 rpm with alignment to the left or right spindle as desired.

Enormous reductions in internal grinding times are achieved by pre-turning to a minimum stock oversize allowance.

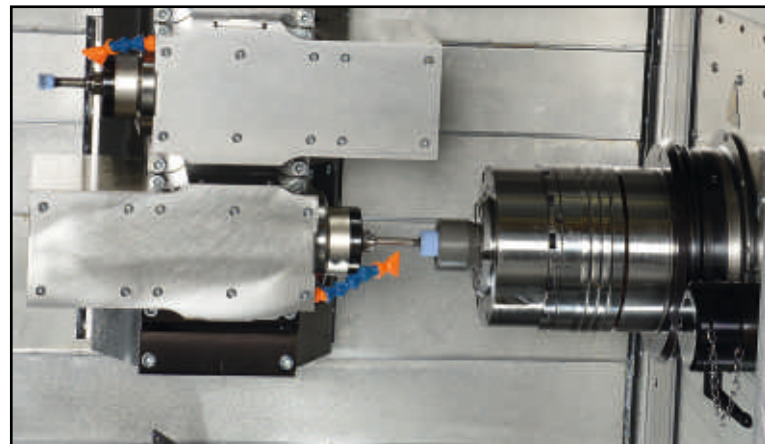

	Microturn Grind 1 spindle	Microturn Grind 2 spindles
Number of spindles	1	2
Grinding wheel outer diameter	400 mm	400 mm
Typical max. workpiece size	D120 x L120 mm	D120 x L120 mm
Number of turret stations	12 x BMT45	12 x BMT45

# TC

Universal  
Stable  
Compact

## Powerful Universal Lathes



■ Hardened and ground sliding guideways for best vibration damping

- Solid sliding guideways with high damping
- Monoblock rigid casting design of machine body
- Tailstock or sub spindle
- Optional Y axis and driven tools
- Modern motor spindles (up to 85 mm)
- Gearboxes for high torques (from 110 mm)
- Latest control system Siemens 840D/ONE or Fanuc 32i



Available with automation

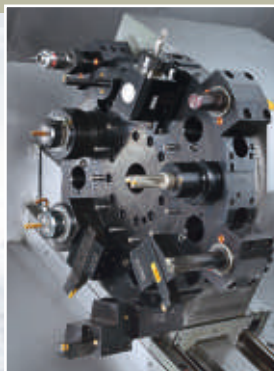

Turret VDI150  
of TC800-MC



Y axis fully integrated in  
the machine bed

Reliable technology  
High precision  
Durable

Turning length from 400 up to 1500 mm



Machine bed TC600

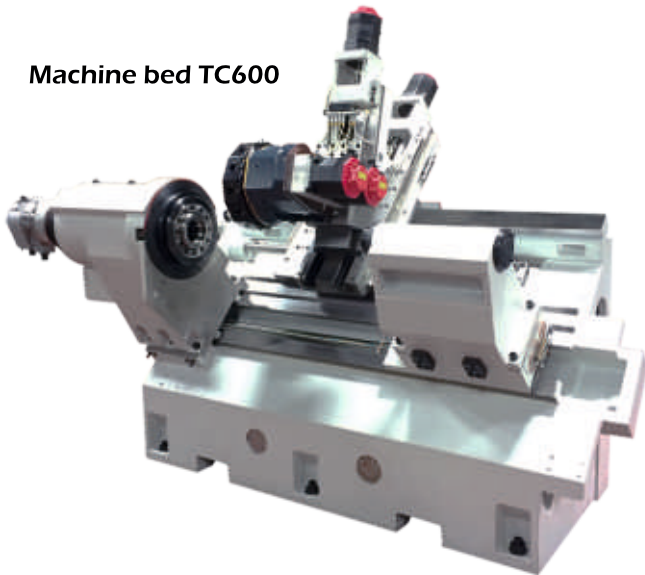

Model sizes

	Bar material up to	Chucks	Max. Turning length
TC300	52 mm	160/210 mm	350 mm
TC400	52 mm	160/210 mm	500 mm
TC600	65/85 mm	250 mm	650 mm
TC610	65/85 mm	250/315 mm	700 mm
TC610L	65/85 mm	250/315 mm	1250 mm
TC800	85/110/175 mm	250/315/400/500 mm	900-1500 mm

# TS

Powerful  
Precise  
Universal

SPINNER TS

## High-performance Universal Lathe

Available in 3  
model sizes:

TS750  
TS850  
TS850XL



TS850

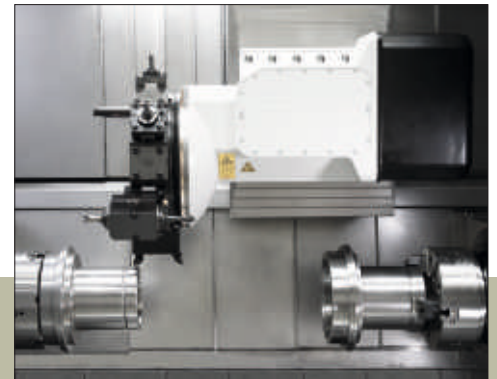

- Motor spindles with water cooling
- Spindle bore 85/125 mm (3.3/4.9 in)
- High-performance design of the machine bed
- Optimum chip fall with perfect covers for guideways
- Rigid turret "Made by SPINNER" with high-precision toolholders BMT

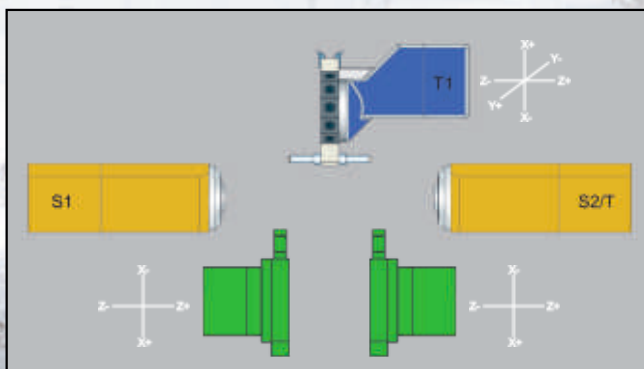

With an upper turret with Y-axis in the working area

Available with sub-spindle or tailstock

Optional steady-rest for TS850/TS850XL

Passive structure damping  
 Large working area  
 Made in Germany

For powerful and universal machining

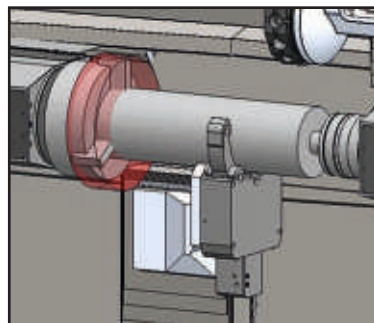
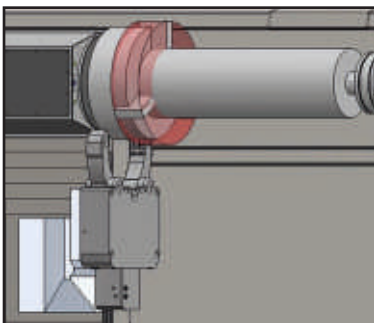

Flexible steady-rests are available that can be programmed to move in two axes on a cross-slide to clamp the part securely quickly and precisely. When not in use, the steady rest is parked in a protected park position.

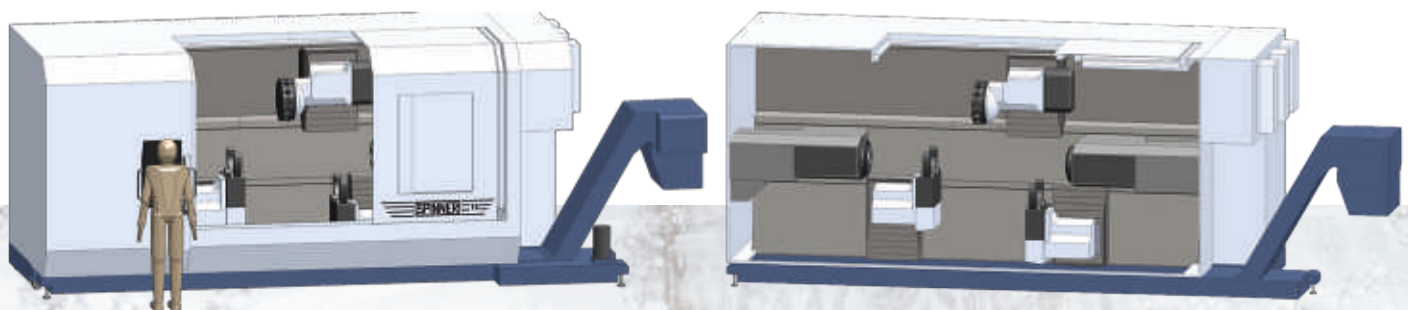

TS850XL

**Model sizes**

	Bar material up to	Chucks	Max. Turning length
TS750	85/125 mm (3.3/4.9 in)	Ø250-450 mm (10-18 in)	1050 mm (41.3 in)
TS850	85/125 mm (3.3/4.9 in)	Ø315-600 mm (12-23 in)	1250 mm (49.2 in)
TS850XL	85/125 mm (3.3/4.9 in)	Ø315-600 mm (12-23 in)	1850 mm (72.8 in)

Powerful  
Highly dynamic  
Highly productive

## Simultaneous machining from bar material or with automation



TTS 42/65

### TTS-Duplex: Two turrets top/bottom

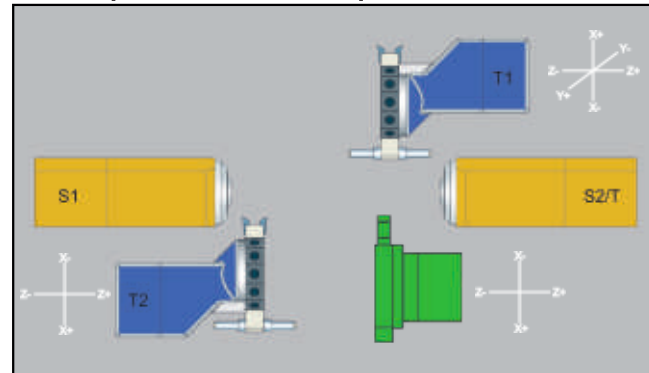

- Perfect covers for guideways
- Integrated motor spindles with water cooling
- Spindle bore 42/65/85/125 mm
- Chips falling perfectly straight downward
- THE productive turning solution for bar machining or with automation
- Reduction of cycle time by simultaneous operations with up to 4 turrets
- Two Y-axes in the TRIPLEX-Version and QUADREX-Version
- Each turret can work either on the main spindle or on the sub spindle
- Increased cutting performance by integrated passive vibration damping
- Rigid turret "Made by SPINNER" with high-precision toolholders BMT

### TTS-Twin: Two turrets at the top

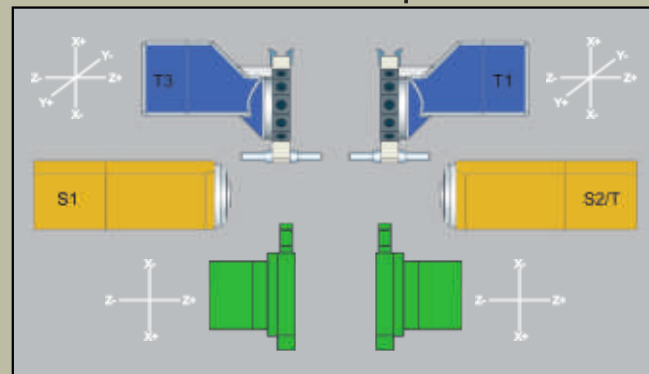

Optional steady-rest for TTS85/125

Passive structure damping  
Increased cutting performance  
Made in Germany

For complex turning AND milling parts



TTS 85/125

### TTS-Triplex: Three turrets

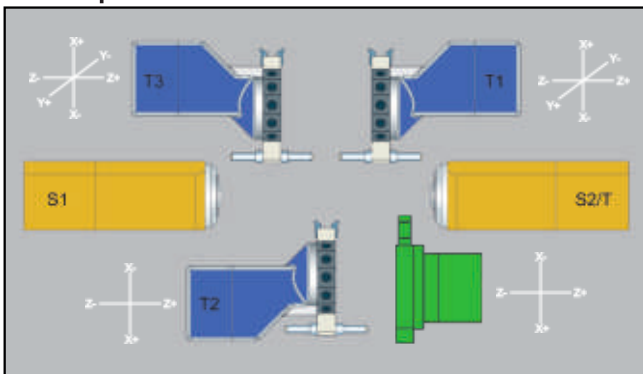

### TTS-Quadrex: Four turrets\*

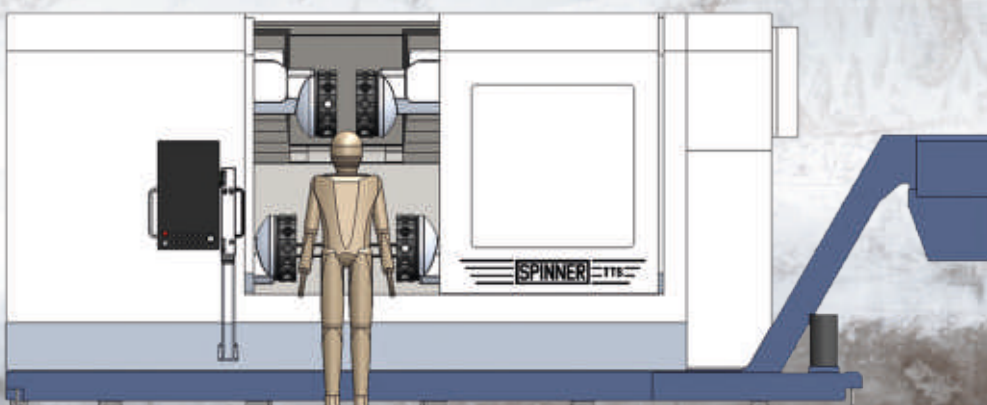
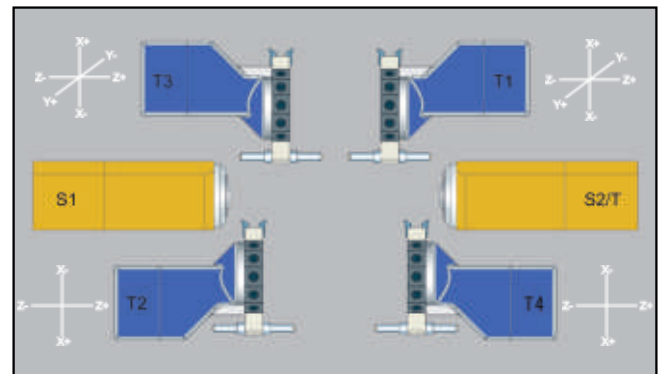

### TTS-Quadrex\*

Top model with four simultaneously operating turrets for high productivity in both bar and chuck machining.

\*Only available for TTS85/125

# U-Compact

Universal  
Compact  
Affordable

## Universal Machining Centre



U630 Compact available in 3 configurations

- U3-630 Compact:  
3-axes-version with fixed table
- U4-630 Compact:  
4-axes-version with large rotary table
- U5-630 Compact:  
5-axes-version with integrated rotary/tilting table



- Large X stroke with 630 mm or 1530 mm
- Both side bearing for tilting-axis
- THE entry-level machine for 5-axes machining

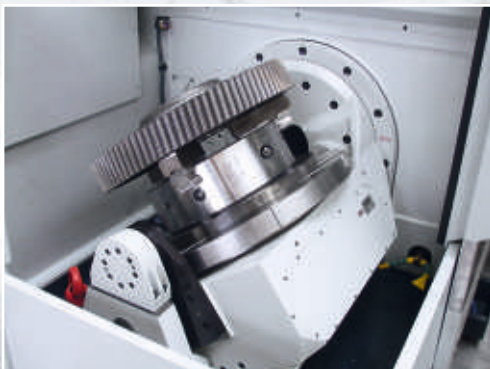

# U-Compact

Dynamic  
Optimal access  
Flexible use

## The entry-level machine for 5-axes machining

U1530 Compact available in 3 configurations

- U3-1530 Compact: 3-axes-version with large fixed table
- U4-1530 Compact: 4-axes-version with large rotary table and fixed table on left side in the working area
- U5-1530 Compact: 5-axes-version with integrated rotary/tilting table and fixed table on left side in the working area

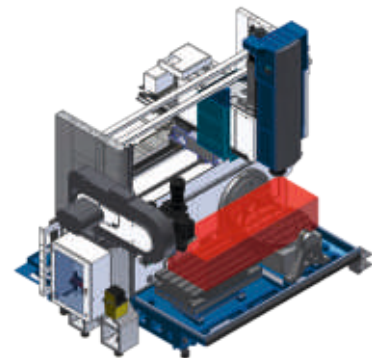
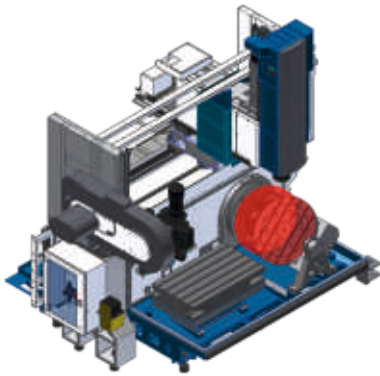

With Heidenhain TNC7 16 inch



### Strokes

	X-axis	Y-axis	Z-axis	B-axis
U630	630 mm	530 mm	465 mm	+110°/-90°
U1530	1530 mm	530 mm	465 mm	+110°/-90°

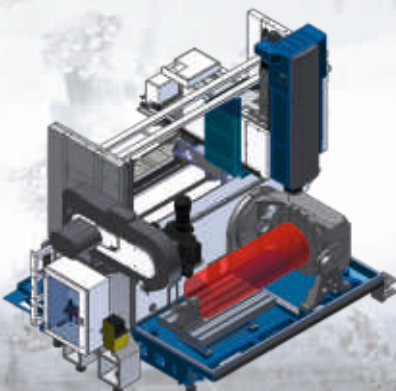

# U-Advanced

Professional 5-axes machining  
Highly dynamic  
Compact and sealed

## Travelling-Column Machining Centre

U1530 available in 3 configurations

- U3-1530: 3-axes-version with large fixed table
- U4-1530: 4-axes-version with large rotary table and fixed table on left side in the working area
- U5-1530: 5-axes-version with integrated rotary/tilting table and fixed table on left side in the working area



U5-1530 with Siemens ONE and 24-inch Touch panel



- With high-precision rotary/tilting tables available with weight compensation
- Extendable up to 122 tools
- Available with pallet changer
- Most modern control systems: Siemens ONE or Heidenhain TNC7
- With most modern digital drives
- Spindle speeds up to 20.000 rpm



Machining example U4 und U5

# U-Advanced

Optimal accuracy  
For tool making and mass producer  
Optimal ergonomics

## For High-End applications

U630 available in 3 configurations

- U3-630: 3-axes-version with fixed table
- U4-630: 4-axes-version with large rotary table
- U5-630: 5-axes-version with integrated rotary/tilting table



U5-630 with Heidenhain TNC7 19 inch



### Strokes

	X-axis	Y-axis	Z-axis	B-axis
U630	630 mm	530 mm	465 mm	+180°/-120° <sup>1) 2)</sup>
U1530	1530 mm	530 mm	465 mm	+180°/-120° <sup>1) 2)</sup>

1) U4 360°  
2) +110°/-90° with T-Table

# VC-3A

Compact  
Highly dynamic  
Quick double arm changer

## High-Performance Machining Centre

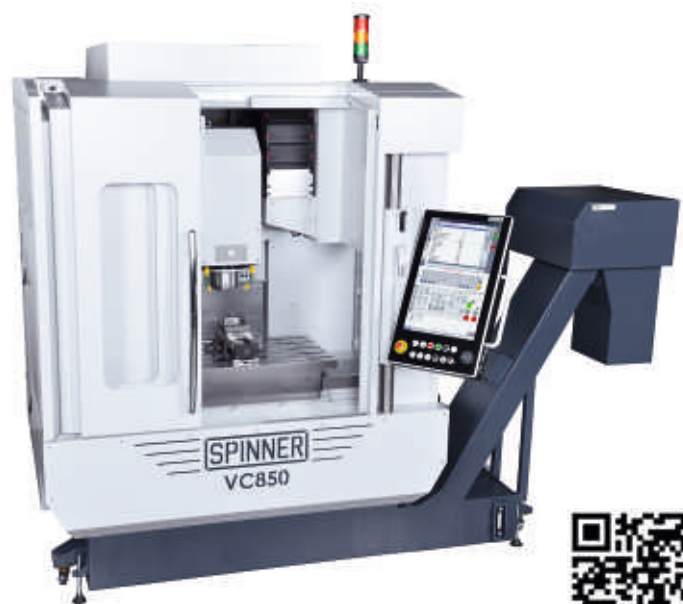

Video VC850

- Full cast design with fixed column
- Mass optimised slides for high rapid traverse
- Large sized linear guides and high dynamics
- Spindle speeds between 8,000 und 24,000 rpm (according to the application)

User interface of the 24-inch Touch panel



Cast structure VC850

# VC-3A

High spindle speeds  
Rigid casting machine bed  
Powerful

For tool and mould making and HSC machining



Video VC1150



Video VC1650



Cast structure VC1650



- Innovative guideway cover concept
- Small distance to the working table
- Adjustable control panel
- FEM optimised cast structure

## Strokes

	X-axis	Y-axis	Z-axis
VC450	450 mm	400 mm	400 mm
VC750	760 mm	460 mm	460 mm
VC850	850 mm	510 mm	510 mm
VC1150	1150 mm	620 mm	600 mm
VC1650-3A	1650 mm	820 mm	820 mm



# VC850-4A/5A

VC850-5A

With integrated 5-axis table  
Highly precise and dynamic



THE high-precision machining centre for  
4-/5-axis machining in the smallest  
installation space.



Compact  
dimensions



Siemens ONE



Heidenhain TNC640



Heidenhain TNC620

# VC850-4A/5A

## VC850-4A

With integrated clamping bridge

With compact dimensions



### Model VC850-4A

With integrated 4th axis and counter bearing support via the clamping rocker.

For multiple clamping processing in series production.



### Model VC850-5A

With integrated 2-axis rotary/tilting table.

For 5-axis machining.  
With additional rigid clamping table next to the rotary axis.  
For workpieces up to D=350 x L300 mm.

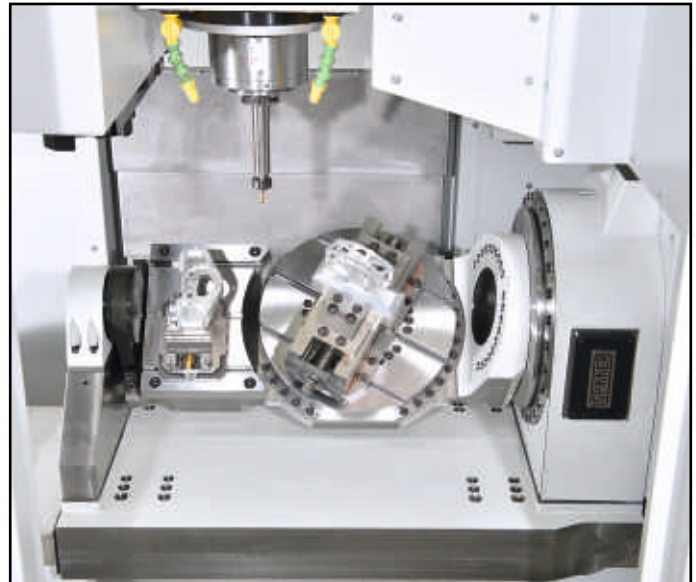

	VC850-4A	VC850-5A
Strokes X/Y/Z	850/510/510 mm	850/510/510 mm
Spindles	12.000/18.000 rpm	12.000/18.000 rpm
4th axis with rocker	X	
4th/5th axis as rotary/tilting table		X

# VC1650-5A

Powerful  
Dynamic  
Ergonomic

## 5-Axes High-Precision Machining Centre

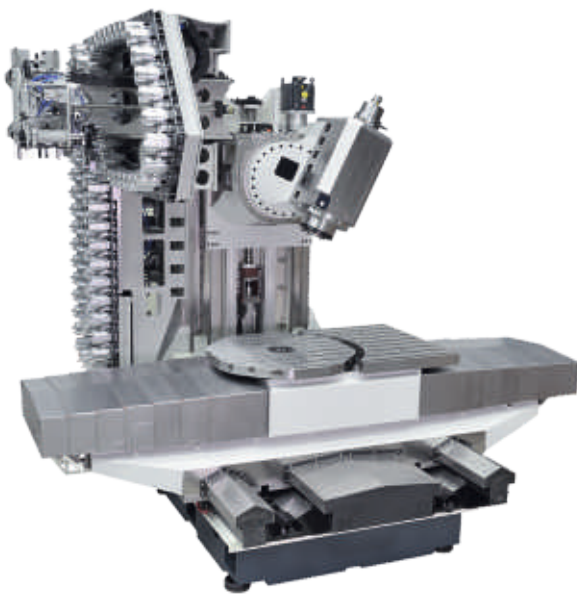

- New and patent-registered guideway cover concept
- Ideal for heavy workpieces
- Additional fixed table for 3-axes machining
- Optimal chip disposal by means of 4 worm conveyors
- Up to 138 tools in the tool magazine

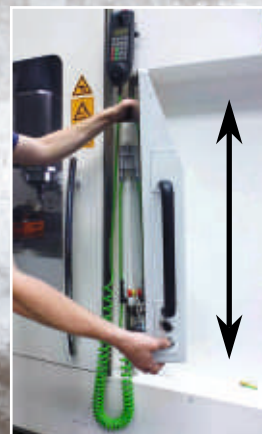

Ergonomic  
operating panel  
adjustable in  
height and angle

# VC1650-5A

Compact  
Large workspace  
Made in Germany

For large workpieces



- Additional fixed table on the right side in the workspace
- Small distance to the working table



## Strokes

	X-axis	Y-axis	Z-axis	Pivot axis B in the milling head
VC1650-5A	1650 mm	820 mm	820 mm	-1° / +110°

# Bar feeder

SERVO-LOAD 80 1500

Compact  
Fast  
Affordable

## Short bar feeders



■ CNC-servo axis for smooth move of the bar

■ For material up to 1200 mm

■ Max. bar diameter 80 mm / 110 mm / 125 mm



	Servo 80-1500	Servo 110-1500
Max. bar length	1500 mm	1500 mm
Bar diameter	6-80 mm	8-110 mm

# Robobox

Compact  
Affordable  
Made in Germany

- Available for almost all SPINNER machines
- Suitable for loading lathes and machining centres
- Can be flexibly positioned as a BOX in front of or next to the machine
- Safely closed for temporary manual operation



- 5 storage drawers
- For workpieces weighing up to 2 x 4 kg or, respectively, 8 kgs
- Programmed in dialog via masks without special knowledge
- Everything from a single source: SPINNER

Video of the ROBOBOX



# Automation

Turn-key projects  
Individual or standard  
Interlinked machines

Fully automated production solutions for large-scale production



Your advantages at one glance

- Increase in productivity
- Cost reduction
- Optimal processes for your machining requirements
- All with certification according to CE



# Automation

Bulk material supply  
Integrated or external  
Palletising

FROM ONE SINGLE SOURCE, SPINNER and SPINNER-Automation



- Most modern digital drive systems
- Convenient dialogue programming
- With special clamping devices and tools

Ask us for your solution!





# SPINNER



## Werkzeugmaschinenfabrik GmbH

### Main factory in Germany

Rudolf-Diesel-Ring 24, D-82054 Sauerlach

Tel: +49/(0)8104 / 803-60

Fax: +49/(0)8104 / 803-19

[sales@spinner.eu.com](mailto:sales@spinner.eu.com)



[www.spinner.eu.com](http://www.spinner.eu.com)

### Other Spinner factories and representatives

#### SPINNER Automation GmbH

Elly-Beinhorn-Straße 4

71706 Markgröningen

Tel. 07145/93508-0

[sales@spinner-automation.de](mailto:sales@spinner-automation.de)



#### SPINNER TAKIM TEZGAHLARI SAN. VE TIC. LTD. STI.

Istanbul Endüstri ve

Ticaret Serbest Bölge Subesi

Aydinli Serbest Bölge Mah., Mod-1 Caddesi

No:1,3,5,7,9,11,13,15,17,19,21,25,27

Tuzla Istanbul Turkey

Tel. 0090/216/394 21 46, [info@spinner.com.tr](mailto:info@spinner.com.tr)



#### SPINNER BULGARIA LTD

Kapsida Industrial Zone

3 Bavaria Street

4101 Kuklen, Plovdiv Region

[info@spinner.bg](mailto:info@spinner.bg)



#### SPINNER Italia S.r.l.

Via Cavalier Streparava, 9

I – 25038 Rovato (BS)

Tel. +39 030 7242 634

[sales.italia@spinner.eu.com](mailto:sales.italia@spinner.eu.com)



#### SPINNER AG, Schweiz

Hauserstraße 35

CH-8451 Kleinandelfingen

Tel. 0041/52/3 01 21 55

[info@spinner-ag.ch](mailto:info@spinner-ag.ch)



#### SPINNER North America LLC

PO Box 1004

Elk River, MN 55330

[customersupport@spinnernorthamerica.com](mailto:customersupport@spinnernorthamerica.com)

Tel. 001-763-220-2901



For further questions please contact your regional sales organisation

Regional Dealer

Technical changes of specifications and pictures are subject to change without notice - Pictures can include options, accessories